

FLUKE®

5320A

Multifunction Electrical Tester Calibrator

Getting Started Manual

PN 2634331

September 2006

© 2006 Fluke Corporation, All rights reserved. Printed in USA
All product names are trademarks of their respective companies.

LIMITED WARRANTY AND LIMITATION OF LIABILITY

Each Fluke product is warranted to be free from defects in material and workmanship under normal use and service. The warranty period is one year and begins on the date of shipment. Parts, product repairs, and services are warranted for 90 days. This warranty extends only to the original buyer or end-user customer of a Fluke authorized reseller, and does not apply to fuses, disposable batteries, or to any product which, in Fluke's opinion, has been misused, altered, neglected, contaminated, or damaged by accident or abnormal conditions of operation or handling. Fluke warrants that software will operate substantially in accordance with its functional specifications for 90 days and that it has been properly recorded on non-defective media. Fluke does not warrant that software will be error free or operate without interruption.

Fluke authorized resellers shall extend this warranty on new and unused products to end-user customers only but have no authority to extend a greater or different warranty on behalf of Fluke. Warranty support is available only if product is purchased through a Fluke authorized sales outlet or Buyer has paid the applicable international price. Fluke reserves the right to invoice Buyer for importation costs of repair/replacement parts when product purchased in one country is submitted for repair in another country.

Fluke's warranty obligation is limited, at Fluke's option, to refund of the purchase price, free of charge repair, or replacement of a defective product which is returned to a Fluke authorized service center within the warranty period.

To obtain warranty service, contact your nearest Fluke authorized service center to obtain return authorization information, then send the product to that service center, with a description of the difficulty, postage and insurance prepaid (FOB Destination). Fluke assumes no risk for damage in transit. Following warranty repair, the product will be returned to Buyer, transportation prepaid (FOB Destination). If Fluke determines that failure was caused by neglect, misuse, contamination, alteration, accident, or abnormal condition of operation or handling, including overvoltage failures caused by use outside the product's specified rating, or normal wear and tear of mechanical components, Fluke will provide an estimate of repair costs and obtain authorization before commencing the work. Following repair, the product will be returned to the Buyer transportation prepaid and the Buyer will be billed for the repair and return transportation charges (FOB Shipping Point).

THIS WARRANTY IS BUYER'S SOLE AND EXCLUSIVE REMEDY AND IS IN LIEU OF ALL OTHER WARRANTIES, EXPRESS OR IMPLIED, INCLUDING BUT NOT LIMITED TO ANY IMPLIED WARRANTY OF MERCHANTABILITY OR FITNESS FOR A PARTICULAR PURPOSE. FLUKE SHALL NOT BE LIABLE FOR ANY SPECIAL, INDIRECT, INCIDENTAL, OR CONSEQUENTIAL DAMAGES OR LOSSES, INCLUDING LOSS OF DATA, ARISING FROM ANY CAUSE OR THEORY.

Since some countries or states do not allow limitation of the term of an implied warranty, or exclusion or limitation of incidental or consequential damages, the limitations and exclusions of this warranty may not apply to every buyer. If any provision of this Warranty is held invalid or unenforceable by a court or other decision-maker of competent jurisdiction, such holding will not affect the validity or enforceability of any other provision.

Fluke Corporation
P.O. Box 9090
Everett, WA 98206-9090
U.S.A.

Fluke Europe B.V.
P.O. Box 1186
5602 BD Eindhoven
The Netherlands

11/99

To register your product online, visit register.fluke.com

Claims

Immediately upon arrival, purchaser shall check the packing container against the enclosed packing list and shall, within thirty (30) days of arrival, give Fluke notice of shortages or any nonconformity with the terms of the order. If purchaser fails to give notice, the delivery shall be deemed to conform with the terms of the order.

The purchaser assumes all risk of loss or damage to instruments upon delivery by Fluke to the carrier. If an instrument is damaged in transit, **PURCHASER MUST FILE ALL CLAIMS FOR DAMAGE WITH THE CARRIER** to obtain compensation. Upon request by purchaser, Fluke will submit an estimate of the cost to repair shipment damage.

Fluke will be happy to answer all questions to enhance the use of this instrument. Please address your requests or correspondence to: Fluke Corporation, P.O. Box 9090, Everett, WA 98206-9090.

Declaration of the Manufacturer or Importer

We hereby certify that the Fluke Models 5320A is in compliance with Postal Regulation Vfg. 1046 and is RFI suppressed. The marketing and sale of the equipment was reported to the German Postal Service. The right to retest this equipment to verify compliance with the regulation was given to the German Postal Service.

Interference Information

This equipment generates and uses radio frequency energy and if not installed and used in strict accordance with the manufacturer's instructions, may cause interference to radio and television reception. It has been type tested and found to comply with the limits for a Class B computing device in accordance with the specifications in Subpart J of Part 15 of FCC Rules, which are designed to provide reasonable protection against such interference in a residential installation. However, there is no guarantee that interference will not occur in a particular installation. If this equipment does cause interference to radio or television reception, which can be determined by turning the equipment off and on, the user is encouraged to try to correct the interference by one of more of the following measures:

- Reorient the receiving antenna
- Relocate the equipment with respect to the receiver
- Move the equipment away from the receiver
- Plug the equipment into a different outlet so that the computer and receiver are on different branch circuits

If necessary, the user should consult the dealer or an experienced radio/television technician for additional suggestions. The user may find the following booklet prepared by the Federal Communications Commission helpful: How to Identify and Resolve Radio-TV Interference Problems. This booklet is available from the U.S. Government Printing Office, Washington, D.C. 20402. Stock No. 004-000-00345-4.

OPERATOR SAFETY SUMMARY

WARNING

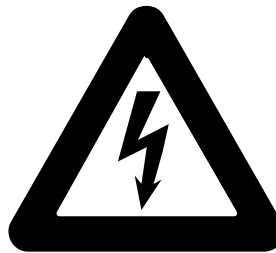

HIGH VOLTAGE

is used in the operation of this equipment

LETHAL VOLTAGE

may be present on the terminals, observe all safety precautions!

To avoid electrical shock hazard, the operator should not electrically contact the output hi or sense hi binding posts. During operation, lethal voltages of up to 1100 V ac or dc may be present on these terminals.

Whenever the nature of the operation permits, keep one hand away from the Calibrator to reduce the hazard of current flowing through vital organs of the body.

Terms in this Manual

This instrument has been designed and tested in accordance with the safety standards listed in the General Specifications. This manual contains information and warnings which have to be followed by the user to ensure safe operation and to retain the instrument in safe condition.

WARNING statements identify conditions or practices that could result in personal injury or loss of life.

CAUTION statements identify conditions or practices that could result in damage to the equipment or other property.

Symbols Marked on Equipment



DANGER — High Voltage



Protective ground (earth) terminal



Attention — refer to the manual. This symbol indicates that information about the usage of a feature is contained in the manual.

Power Source

The 5320A is intended to operate from a power source that will not apply more than 264V ac rms between the supply conductors or between either supply conductor and ground. A protective ground connection by way of the grounding conductor in the power cord is essential for safe operation.

Use the Proper Fuse

To avoid fire hazard, use only the fuse specified in Table 2 for the selected line.

Grounding the 5320A

The 5320A is a Safety Class I (grounded enclosure) instrument as defined in IEC 348. The enclosure is grounded through the grounding conductor of the power cord. To avoid electrical shock, plug the power cord into a properly wired earth grounded receptacle before connecting anything to any of the 5320A terminals. A protective ground connection by way of the grounding conductor in the power cord is essential for safe operation.

Use the Proper Power Cord

Always use the power (line) cord and connector appropriate for the voltage and outlet of the country or location in which you are working.

Always match the line cord to the instrument.

- Use the AC line cord supplied with this instrument with this instrument only.
- Do not use this line cord with any other instruments.
- Do not use any other line cords with this instrument.

Use only the power cord and connector appropriate for proper operation of a 5320A in your country.

Use only a power cord that is in good condition.

For detailed information on power cords, refer to Table 4 and Figure 1.

Refer cord and connector changes to qualified service personnel.

Do Not Operate in Explosive Atmospheres

To avoid explosion, do not operate the 5320A in an atmosphere of explosive gas.

Do Not Remove Cover

To avoid personal injury, do not remove the cover from the 5320A. Do not operate the 5320A without the cover properly installed. There are no user-serviceable parts inside the 5320A, so there is no need for the operator to ever remove the cover.



FIRST AID FOR ELECTRIC SHOCK

Free the Victim From the Live Conductor

Shut off high voltage at once and ground the circuit. If high voltage cannot be turned off quickly, ground the circuit.

Get Help!

Call loudly for help. Call an emergency number. Request medical assistance.

Never Accept Ordinary and General Tests for Death

Symptoms of electric shock may include unconsciousness, failure to breathe, absence of pulse, pallor, and stiffness, and well as severe burns.

Treat the Victim

If the victim is not breathing, begin CPR or mouth-to-mouth resuscitation if you are certified.

Table of Contents

Title	Page
Introduction.....	1
Calibrator Functions	1
Function Descriptions.....	1
Instruction Manuals	3
5320A Getting Started Manual.....	3
5320A Users Manual.....	3
Contacting Fluke.....	3
General Specifications	4
Electrical Specifications	4
Low Resistance Source.....	4
High Resistance Source.....	5
Ground Bond Resistance Source	5
Line/Loop Impedance Source.....	6
Leakage Current Source	8
RCD (Residual Current Device).....	8
AC/DC Voltage Calibrator (5320A/VLC only)	8
Multimeter	9
Unpacking and Inspection.....	10
Service Information	11
Placement and Rack Mounting	11
Cooling Considerations.....	12
Selecting Line Voltage.....	12
Accessing the Fuses	12
Line-Power Fuse.....	12
Measurement Input Fuses.....	13
Connecting to Line Power	13
Calibrator Safety Class Rating.....	15
Description of IEC 61010 Measurement Categories	15
Front-Panel Features	16
Display Features	19
Rear-Panel Features	20
Turning on the Calibrator.....	21
Warm Up.....	22
Accessories	23
5320A Service Manual	24

List of Tables

Table	Title	Page
1.	Standard Equipment	11
2.	Line Power Fuses	13
3.	Measurement Input Fuses.....	13
4.	Line Power Cord Types Available from Fluke	14
5.	Front-Panel Features	16
6.	Display Features.....	19
7.	Rear-Panel Features	20
8.	Function Default Settings.....	22
9.	Accessories.....	23

List of Figures

Figure	Title	Page
1.	Line Power Cords Types Available from Fluke.....	14
2.	IEC 61010 Measurement Category (CAT) Levels.....	15
3.	Power-up Test Results Screen.....	21
4.	Meter Mode (Reference State) Display.....	22

Getting Started

Introduction

The Fluke 5320A and 5320A/VLC are Multifunction Electrical Tester Calibrators (hereafter referred to as the Calibrator), designed for full calibration and testing of electrical safety testers. Some examples of these testers are:

- Megohm meters
- Ground bond testers
- Loop testers
- RCD testers
- Appliance testers
- Electrical installation testers
- Earth resistance meters
- High voltage safety testers (Hipots)

Calibrator Functions

The Calibrator performs output and measurement functions.

Output Functions:

- Insulation resistance
- Earth resistance and continuity
- Loop, line and ground bond resistance
- Residual Current Device (RCD)/Ground Fault Circuit Interrupter (GFCI) testing
- Leakage current source
- AC/DC voltage generation (5320A/VLC only)

Measurement functions:

- AC/DC voltage and current measuring
- Load current, power consumption

Function Descriptions

The following sections describe various functions of the Calibrator. Unless otherwise noted, the following descriptions apply to both 5320A and 5320A/VLC.

Insulation Resistance

For insulation resistance calibration, the Calibrator acts as a high resistance source from 10 k Ω to 10 G Ω with 4½ digit resolution. A single value 100 G Ω selection is available as well. Depending on the selected resistance value, maximum applied test voltages range from 50 to 1500 volts peak.

Earth Resistance and Continuity

The Calibrator sources low resistance values from 100 m Ω to 10 k Ω with 3½ digits of resolution. This function is used in either 2-wire or 4-wire mode to calibrate continuity testers and earth resistance testers that source currents from 5 to 400 mA.

Loop, Line and Ground Bond Resistance

The Calibrator sources high power rated low resistance standards from 25 m Ω to 1.8 k Ω , which are especially suited for loop impedance, line impedance, and ground bond resistance testing. The Calibrator senses and displays Unit Under Test (UUT) test conditions, types of test current, and current levels up to 25 amps. In the 5320A/VLC, an Active Loop Compensation module will compensate for residual resistance when performing loop and line impedance calibrations.

Residual Current Device Testing

In the RCD function, the Calibrator acts as a circuit breaker to calibrate trip time in the range of 10 ms to 5 s and trip current in the range of 3 mA to 3 A. All tested parameters of the UUT are scanned and displayed through the Calibrator's front-panel display.

Leakage Current Source

The Calibrator sources simulated leakage current from 0 to 30 mA with a maximum compliance voltage up to 250 V ac. Leakage current modes include touch, substitute and differential current.

AC/DC Voltage Generation (5320A/VLC Only)

When equipped with the AC/DC voltage calibrator, the Calibrator is capable of calibrating the voltmeter function on many electrical safety testers. The voltage range is 3 to 600 volts both ac and dc. The ac frequency range is 40 to 400 Hz. This voltage source also generates stable power line voltage for powering appliance testers.

Meter Functions

The Calibrator is equipped with a built-in low frequency voltmeter and ammeter. The voltmeter measures up to 1100 volts, while the ammeter measures up to 30 amps. UUT power consumption is calculated by taking the measured voltage and current and then calculating the VA.

Other Features

For ease of use, the Calibrator includes other features such as setup menus, a recalibration procedure, correct power line connection testing, hardware and software overload protection, and many others.

Front-panel control of the Calibrator is accomplished through function keys for frequently used functions, edit controls and menu selection soft keys. All necessary information such as Calibrator status, menu selections and readings are displayed through a flat luminescent display on the front panel.

The Calibrator is equipped with an IEEE-488 bus, an RS-232 serial port and a LAN interface, for controlling the Calibrator from a PC or instrument controller.

Instruction Manuals

The Calibrator ships with a manual set that contains information for the user and programmer. The set includes:

- 5320A Getting Started Manual (PN 2634331)
- 5320A Users Manual (CD ROM, PN 2634346)

Order additional copies of these manuals using the part numbers provided. For ordering instructions, refer to a Fluke catalog or contact a Fluke sales representative.

5320A Getting Started Manual

Use this manual for basic getting started information, contacting Fluke, unpacking, and general specifications. This manual also provides setup and operation information for the Calibrator, descriptions of the Calibrator's front and rear-panel features, and information about setting up and powering up the Calibrator. Please read this information before operating the Calibrator.

5320A Users Manual

The Users Manual is available in PDF format on the CD-ROM provide with your Calibrator. It contains information on operating the Calibrator from the front panel. The *Calibrating Instruments* section explains the Calibrator's functions and the steps necessary to use them. In addition to operational instructions, this manual also contains information on general maintenance and a verification procedure to ensure the Calibrator is operating within specifications.

Contacting Fluke

To order accessories, receive operating assistance, or get the location of the nearest Fluke distributor or Service Center, call:

USA:	1-800-44-FLUKE (1-800-443-5853)
Canada:	1-800-36-FLUKE (1-800-363-5853)
Europe:	+31 402-678-200
Japan:	+81-3-3434-0181
Singapore:	+65-738-5655
Anywhere in the world:	+1-425-446-5500
Service in USA:	1-888-99-FLUKE (1-888-993-5853)

Or, visit Fluke's Web site at www.fluke.com. To register this product, visit register.fluke.com

General Specifications

Warm-Up Time	30 minutes
Specifications Confidence Interval	99%
Temperature Performance	
Operating Temperature	18 to 28 °C
Calibration Temperature (tcal)	23 °C
Temperature Coefficient	Temperature coefficient for temperature outside of Tcal ±5 °C between +5 °C to +40 °C is 0.1 x /°C
Storage Temperature.....	-20 to +70 °C
Relative Humidity (operating)	<70% to 28 °C
Altitude	
Operating	3,050 m (10,000 ft.)
Storage	12,200 m (40,000 ft.)
Dimensions	450 mm X 480 mm X 170 mm (17.7 in. X 18.9 in. X 6.7 in.)
Weight	18 kg (39.7 lbs.)
Power Line	115/230 V ac (50/60 Hz) ±10 %
Power Consumption	150 VA Maximum
Safety Class	Class I, according to EN 61010-1
Electrostatic Discharge	This instrument meets class I for ESD requirements per EN 61326
⚠ Fuse Protection	
AC mains input	2 A, 250 V for 230 V (T2L250V) 4 A, 250 V for 115 V (F4L250V)
RCD input	3.15 A, 250 V (F3.15L250V)
Meter amps (A) input	20 A, 500 V (F20L500V)
Loop/Line impedance input.....	4 A, 250 V (T4L250V)
Leakage current input.....	100 mA, 250V (F100mAL250V)

Electrical Specifications

Low Resistance Source

Total Range	100 mΩ to 10 kΩ
Resolution	3½ digits (continuously variable)

Uncertainty and Maximum Ratings

Range	Resolution	Maximum AC or DC Current ^[1]	2-Wire Uncertainty ^[2] (tcal ±5 °C)	4-Wire Uncertainty (tcal ±5 °C)
100 mΩ to 4.99 Ω	0.1 mΩ	400 mA	0.3 % + 25 mΩ	0.3 % + 10 mΩ
5 to 29.9 Ω	0.01 Ω	250 mA	0.2 % + 25 mΩ	0.2 % + 10 mΩ
30 to 199.9 Ω	0.1 Ω	100 mA	0.2 % + 25 mΩ	0.2 % + 10 mΩ
200 to 499 Ω	1 Ω	45 mA	0.2 %	0.2 %
500 Ω to 1.999 kΩ	1 Ω	25 mA	0.2 %	0.2 %
2 to 4.99 kΩ	10 Ω	10 mA	0.2 %	0.2 %
5 to 10 kΩ	10 Ω	5 mA	0.2 %	0.2 %

Note: [1] Test current can exceed 120% of maximum current for less than 3 seconds. Terminals disconnect if test current exceeds 120% of specified maximum current.

[2] Uncertainty is valid to 200 mW. For higher power rating, add 0.1% per each 300 mW above 200 mW.

Test Current Measurement

Range	0 to 400 mA ac + dc rms
Resolution	1 mA
Uncertainty	$\left(\left(\frac{20}{\sqrt{R}} \right) + 0.1 \right) mA$ R = set resistance between 0.5 Ω to 10 kΩ.

Short Mode

Nominal resistance <50 mΩ
Maximum current 400 mA ac + dc rms

Open Mode

Nominal resistance 30 MΩ ±20 %
Maximum input voltage allowed 50 V ac + dc rms
Test voltage reading 0 to 50 V ac + dc rms
Resolution 1 V
Uncertainty 5 % + 2 V

High Resistance Source

Range 10 kΩ to 10 GΩ plus 100 GΩ single value selection.
Resolution 4½ Digit (continuously variable for 10 kΩ to 10 GΩ range)

Uncertainty and Maximum Ratings

Range	Resolution	Maximum Voltage (ac+dc) Peak	Uncertainty ^[1] (tcal ±5 °C)
10.000 to 39.99 kΩ	1 Ω	55 V	0.2 %
40.00 to 99.99 kΩ	10 Ω	300 V	0.2 %
100.00 to 199.99 kΩ	10 Ω	800 V	0.2 %
200.0 to 999.9 kΩ	100 Ω	1100 V	0.2 %
1.0000 to 9.999 MΩ	100 Ω	1100 V	0.3 %
10.000 to 99.99 MΩ	1 kΩ	1575 V ^[2]	0.5 %
100.00 to 999.9 MΩ	10 kΩ	1575 V ^[2]	1.0 %
1.0000 to 10.000 GΩ	100 kΩ	1575 V ^[2]	3.0 %
100 GΩ	NA	1575 V ^[2]	5.0 % ^[3]

Notes:
 [1] Uncertainty is valid to 500 volts. For test voltages above 500 V, add 0.1% for each 200 V above 500 V.
 [2] Maximum test voltage with the supplied banana leads is 1000 Vrms. For higher voltages, use leads rated at 1575 V or above.
 [3] Calibration value uncertainty is specified in the table. Nominal value uncertainty is 15 %.

Test Voltage Measurement

Range 0 to 2000 V dc peak
Resolution 1 V
Uncertainty 1 % + 5 V for R above 1 MΩ
1 % + 2 V for R below 1 MΩ
Settling Time 2 seconds for input deviations of <5 %

Short Mode

Nominal resistance <100 Ω
Maximum input current allowed 50 mA ac + dc rms
Test current range 0 to 50 mA ac + dc rms
Resolution 0.1 mA
Uncertainty 2% + 0.5 mA

Resistance Multiplier Adapter (x1000 multiplier)

Resistance range 350 MΩ to 10 TΩ
Uncertainty Uncertainty of resistor to be multiplied, +3 % of multiplied value
Maximum test voltage 5500 V dc

Ground Bond Resistance Source

Range 25 mΩ to 1.8 kΩ
 Resolution 16 discrete values
 Minimum test voltage/current 10 V/ 10 mA

Uncertainty and Maximum Ratings

Nominal Value	Deviation from Nominal Value	Absolute Uncertainty of Characterized Value (tcal ±5 °C)	Maximum Continuous Test Current ACrms or DC ^[1]	Test Current Resolution	Test Current Uncertainty
25 mΩ	±50 %	± 10 mΩ	30 A	100 mA	1.5 % + 0.7 A
50 mΩ	±50 %	± 10 mΩ	28 A	100 mA	1.5 % + 0.5 A
100 mΩ	±30 %	± 15 mΩ	25 A	100 mA	1.5 % + 0.35 A
330 mΩ	±20 %	± 15 mΩ	18 A	100 mA	1.5 % + 0.3 A
500 mΩ	±10%	± 20 mΩ	10 A	100 mA	1.5 % + 0.2 A
1 Ω	±10 %	± 20 mΩ	8 A	10 mA	1.5 % + 150 mA
1.8 Ω	±10%	± 30 mΩ	6 A	10 mA	1.5 % + 100 mA
5 Ω	±10 %	± 50 mΩ	3.2 A	10 mA	1.5 % + 70 mA
10 Ω	±10 %	± 80 mΩ	2.0 A	10 mA	1.5 % + 50 mA
18 Ω	±10 %	± 150 mΩ	1.5 A	10 mA	1.5 % + 30 mA
50 Ω	±10 %	± 300 mΩ	0.8 A	1 mA	1.5 % + 20 mA
100 Ω	±10 %	± 500 mΩ	0.5 A	1 mA	1.5 % + 10 mA
180 Ω	±10 %	± 1 Ω	0.25 A	1 mA	1.5 % + 5 mA
500 Ω	±10 %	± 2.5 Ω	0.1 A	1 mA	1.5 % + 3 mA
1 kΩ	±10 %	± 5 Ω	0.05 A	1 mA	1.5 % + 2 mA
1.8 kΩ	±10 %	± 10 Ω	0.025 A	1 mA	1.5 % + 2 mA

Notes:

- [1] Test currents up to 30 % of maximum continuous test current can be applied to the Calibrator with no time limitation. Test current between 30 % and 100 % of the maximum continuous test current can be applied to the Calibrator for a limited time. Minimum period of full current load is 45 seconds. The Calibrator calculates the allowed time period and when exceeded, the output connectors are disconnected.

Test Current Measurement

Range 0 to 40 A ac+ dc rms
 Resolution 1 mA to 100 mA depending on resistance output and test current

Open Mode

Nominal resistance >100 kΩ
 Maximum voltage 50 V ac+dc rms
 Test voltage range 0 to 50 V ac+dc rms
 Resolution 1 V
 Uncertainty 2 % + 2 V

Line/Loop Impedance Source

Range 25 mΩ to 1.8 kΩ
 Resolution 16 discrete values
 Minimum test voltage/current 10 V/10 mA

Uncertainty and Maximum Ratings

Nominal Resistance Value	Deviation from Nominal Value	Absolute Uncertainty of Characterized Value (tcal ± 5 °C)	Maximum Continuous Test Current AC rms or DC ^[1]	Maximum Short-term Test Current AC rms or DC ^[2]	Test Current Uncertainty
25 m Ω	± 50 %	± 10 m Ω	30 A	40 A	1.5 % + 0.7 A
50 m Ω	± 50 %	± 10 m Ω	28 A	40 A	1.5 % + 0.5 A
100 m Ω	± 30 %	± 15 m Ω	25 A	40 A	1.5 % + 0.35 A
330 m Ω	± 20 %	± 15 m Ω	18 A	40 A	1.5 % + 0.3 A
500 m Ω	± 10 %	± 20 m Ω	10 A	40 A	1.5 % + 0.2 A
1 Ω	± 10 %	± 20 m Ω	8 A	40 A	1.5 % + 150 mA
1.8 Ω	± 10 %	± 30 m Ω	6 A	30 A	1.5 % + 100 mA
5 Ω	± 10 %	± 50 m Ω	3.2 A	21 A	1.5 % + 70 mA
10 Ω	± 10 %	± 80 m Ω	2.0 A	15 A	1.5 % + 50 mA
18 Ω	± 10 %	± 150 m Ω	1.5 A	10 A	1.5 % + 30 mA
50 Ω	10 %	± 300 m Ω	0.8 A	5.0 A	1.5 % + 20 mA
100 Ω	10 %	± 500 m Ω	0.5 A	3.0 A	1.5 % + 10 mA
180 Ω	10 %	± 1 Ω	0.25 A	1.35 A	1.5 % + 5 mA
500 Ω	10 %	± 2.5 Ω	0.1 A	0.6 A	1.5 % + 3 mA
1 k Ω	10 %	± 5 Ω	0.05 A	0.3 A	1.5 % + 2 mA
1.8 k Ω	10 %	± 10 Ω	0.025 A	0.15 A	1.5 % + 2 mA

Notes:

[1] Test currents up to 30 % of maximum continuous test current can be applied to the Calibrator with no time limitation. Test current between 30 % and 100 % of the maximum continuous test current can be applied to the Calibrator for a limited time. Minimum period of full current load is 45 seconds. The Calibrator calculates the allowed time period and when exceeded, the output connectors are disconnected.

[2] Maximum short term test current is defined as the rms value of halfwave or fullwave test current flowing through the UUT. Maximum time of test is 200 ms. A time interval of 200 ms represents 10 full waves of power line voltage at 50 Hz and 12 full waves at 60 Hz.

Test Current Measurement

Type of recognized test current Positive impulse (halfwave), negative impulse (halfwave), symmetrical (fullwave).

Range 0 to 40 A ac+dc rms

Resolution 1 to 100 mA depending on test current and resistance output

Prospective Fault Current

Range 0 to 10 kA

Correction Manual Mode

Residual Impedance Range 0 to 10 Ω

Resolution 1 m Ω

Uncertainty Uncertainty in manual (MAN) mode is the uncertainty of the setup resistor used. See table above. Also, the uncertainty of the manually entered correction should be taken into consideration.

Correction Scan Mode

Residual Impedance Range 0 to 10 Ω

Resolution 1 m Ω

Uncertainty Resulting uncertainty in SCAN mode is the sum of uncertainty of the scanned residual resistance and uncertainty of the set resistor per the above table, expressed in ohms.

Correction COMP Mode (Active Loop Compensation) (5320A/VLC only)

Residual Impedance Range	0 to 2 Ω
Maximum Test Current	<25/N A pk, where N equals number of UUT generated test current periods.
Uncertainty of compensation	15 m Ω . Resulting uncertainty in COMP mode is the sum of the uncertainty of the compensated residual resistance and the uncertainty of the setup resistor used per the above table, expressed in ohms. Uncertainty is valid at the point in time when the COMP function is initiated.

Leakage Current Source

Range	0.1 to 30 mA
Resolution:	
Passive Mode	10 μ A setting, 1 μ A measurement
Differential Mode	10 μ A setting, 1 μ A measurement
Substitute Mode	10 μ A
Active Mode (5320A/VLC only)	10 μ A
Test Voltage:	
Passive Mode	60 to 250 V ac+dc rms
Differential Mode	60 to 250 V ac+dc rms
Substitute Mode	10 to 250 V ac+dc rms
Active Mode (5320A/VLC only)	50 to 100 V ac+dc rms
Uncertainty:	
Passive Mode	0.3 % + 2 μ A ac+dc rms
Differential Mode	0.3 % + 2 μ A ac+dc rms Test uncertainty can be influenced by power line voltage instability
Substitute Mode	0.3 % + 2 μ A ac+dc rms
Active Mode (5320A/VLC only)	0.3 % + 1 μ A ac+dc rms

RCD (Residual Current Device)

Trip Current Range:	
0.5 X I and 1 X I mode:	3 to 3000 mA in 1 mA steps
1.4 X I and 2 X I Mode	3 to 1500 mA in 1 mA steps
5 X I Mode	3 to 600 mA in 1 mA steps
Trip Current Measurement Resolution	1 μ A on 30 mA range 10 μ A on 300 mA range 100 μ A on 3A range
Uncertainty:	
0.5 X I and 1 X I mode:	1 % rms
1.4 X I and 2 X I Mode	2 % rms
5 X I Mode	5 % rms
Trip Time Range	10 to 5000 ms
Trip Time Uncertainty	0.25 ms
Series Resistance	0.025 Ω , 0.05 Ω , 0.1 Ω , 0.33 Ω , 0.5 Ω , 1 Ω , 1.8 Ω , 5 Ω , 10 Ω , 18 Ω , 50 Ω , 100 Ω , 180 Ω , 500 Ω , 1000 Ω , 1800 Ω
Line/Touch Voltage Range	250 V
Line/Touch Voltage Uncertainty	5 % + 3 V

AC/DC Voltage Calibrator (5320A/VLC only)

Range	3 to 600 V, ac or dc
Resolution	4 digits
Internal Ranges:	
AC Mode	30, 100, 300, and 600 V (Autoranging only)
DC Mode	30, 150, and 600 V (Autoranging only)

Frequency:
 Range 40 to 400 Hz
 Resolution 3 digits
Settling Time 300 ms to 3 s, depending on output value

AC Voltage

Uncertainty and Maximum Burden Current

Range	Resolution	Uncertainty ±(% of Reading + mV)	Maximum Burden Current
3 – 29.99 V	0.001 V	0.1 % + 9	500 mA
30 – 99.99 V	0.01 V	0.1 % + 30	300 mA
100 – 299.9 V	0.1 V	0.1 % + 90	150 mA
300 – 600 V	0.1 V	0.1 % + 180	50 mA

DC Voltage

Uncertainty and Maximum Burden Current

Range	Resolution	Uncertainty ±(% of Reading + mV)	Maximum Burden Current
3 – 29.99 V	0.001 V	0.1 % + 9	2 mA
30 – 149.9 V	0.01 V	0.1 % + 45	3 mA
150 – 600 V	0.1 V	0.1 % + 180	5 mA

AC Output Signal Distortion 0.2 % ±10 mV (harmonic distortion and non-harmonic noise from 20 Hz to 500 kHz), for output power lower than 10 VA on each range.

Sensing Ammeter Current Range 500 mA

Resolution 1 mA

Uncertainty ±5 mA

Multimeter

Voltage

Range 0 to 1100 V ac rms or dc
Resolution 4½ digits
Internal Ranges 10, 100, and 1100 V (Autoranging only)
Frequency Range DC, 20 Hz to 2 kHz
Input Resistance 10 MΩ ±1 %
Time Constant 1.5 s
Readings/Second 2
Safety class 1000V CAT I, 300 V CAT II

AC/DC Voltage Uncertainty

Range	Resolution	Uncertainty ±(% of Reading + mV)
10 V	0.001 V	0.15 % + 5
100 V	0.01 V	0.20 % + 50
1100 V	0.1 V	0.20 % + 550

Current

Range 0 to 20 A continuous, 30 A for up to 30 minutes, ac rms or dc
Resolution 4½ digits
Internal Ranges 300 mA, 3 and 30 A (Autoranging only)
Frequency Range DC, 20 to 400 Hz
Time Constant 1.5 s
Readings/Second 2

AC/DC Current Uncertainty

Range	Resolution	Uncertainty ±(% of Reading + mA)
300 mA	0.1 mA	0.15 % + 0.15
3 A	1 mA	0.15 % + 1.5
30 A	10 mA	0.30 % + 15

Phantom Power

Range	0 to 33 kVA
Resolution	3 digits
Uncertainty	$\sqrt{(V_{unc})^2 + (I_{unc})^2}$ where V_{unc} is specified uncertainty of measured voltage and I_{unc} is specified uncertainty of measured current.

10 kV Adapter (1000:1 voltage divider)

Range	0 to 10 kV ac rms/dc
Resolution	4½ digits
Uncertainty	0.3 % of value + 5 V dc 0.5 % of value + 5 V ac at 50 or 60 Hz

80K-40 High Voltage Probe

Range	0 to 40 kV ac rms/dc
Resolution	4½ digits
Uncertainty	0.5 % of value + 10 V dc 0.5 % of value + 10 V ac at 50 or 60 Hz

Unpacking and Inspection**⚠ Warning**

The Calibrator is capable of supplying lethal voltages. To avoid electric shock, do not touch the Calibrator's output terminals. Read this section before operating the Calibrator.

The Calibrator is shipped in a container that is specially designed to prevent damage during shipping. Inspect the Calibrator carefully for damage, and immediately report any damage to the shipper. Instructions for inspection and claims are included in the shipping container.

If you need to reship the Calibrator, use the original container. If it is not available, you can order a new container from Fluke by identifying the Calibrator's model and serial number.

When you unpack the Calibrator, check for all the standard equipment listed in Table 1. Report any shortage to the place of purchase or to the nearest Technical Service Center. Visit Fluke web site for Service Center locations.

If performance tests are required for your acceptance procedures, refer to Chapter 6 of the 5320A Users Manual for instructions. Line power cords available from Fluke are listed in Table 4 and illustrated in Figure 1.

Table 1. Standard Equipment

Item	Model or Part Number
Multifunction Electrical Tester Calibrator	5320A or 5320A/VLC
Line Power Cord	See Table 4 and Figure 1
5320A Getting Started Manual	2634331
5320A User Documentation CD (Getting Started & Users Manuals)	2634346
10 KV Adapter – 1000:1 Voltage divider and resistance multiplier.	2743421
Spare Fuses	See Tables 2 and 3 for a list of fuses with part numbers.
Cable adapter - Line plug to 3 banana plugs ^[1]	2743368 (United Kingdom) 2743387 (Europe) 2743400 (Australia/New Zealand)
Cable adapter - Line socket to 3 banana plugs ^[1]	2743379 (United Kingdom) 2743393 (Europe) 2743417 (Australia/New Zealand)
Test lead 1000 V/32 A/50 cm banana-banana red	2743442
Test lead 1000 V/32 A/50 cm banana-banana blue	2743439
Test lead 1000 V/32 A/50 cm banana-banana green	2743456
Test lead 1000 V/32 A/50 cm banana-banana black	2743463
Plug adapter (x2)	2743474
Notes: [1] Only one of the items in the right column is shipped with each Calibrator.	

Service Information

Each Calibrator is warranted to the original purchaser for a period of one year beginning on the date received. The warranty is located at the front of this manual.

Factory-authorized service and technical advice for the Calibrator is available at Fluke Service Centers. A complete list of service centers is available at www.fluke.com.

⚠⚠ Warning

Servicing described in this manual is to be done by qualified service personnel only. To avoid electrical shock, do not service the Calibrator unless you are qualified to do so.

Placement and Rack Mounting

Place the Calibrator on top of a bench or mounted in a standard-width, 24-inch (61-cm) deep equipment rack. For bench-top use, the Calibrator is equipped with non-slipping, non-marring feet. To mount the Calibrator in an equipment rack, use the Rack Mount Kit, Model Y5320A, instructions are included with the kit. For convenience, the rack mount instruction sheet can be stored in the binder of this manual.

Cooling Considerations

⚠ Caution

Damage caused by overheating may occur if the area around the air intake is restricted, the intake air is too warm, or the fan filter becomes clogged.

Accuracy and dependability of all internal parts of the Calibrator are enhanced by maintaining the coolest possible internal temperature. By observing the following rules, you can lengthen the life of the Calibrator:

- The area around the fan filter must be at least 3 inches from nearby walls or rack enclosures.
- Exhaust perforations on the sides of the Calibrator must be clear of obstructions. Most of the heat exits from the side vents.
- Air entering the instrument must be room temperature. Make sure that exhaust from another instrument is not directed into the fan inlet.
- Clean the fan filter every 30 days, or more frequently if the Calibrator is operated in a dusty environment. (Instructions for cleaning the fan filter are in Chapter 2 of the Users Manual)

Selecting Line Voltage

The Calibrator will operate on two different input line voltages. The present line voltage setting is indicated on the outside of the line voltage switch found on the Calibrator's rear panel.

To change the line voltage:

1. Disconnect the Calibrator from line power by unplugging the power cable.
2. Using a flat-blade screwdriver, rotate the switch until the desired voltage is under the arrowhead on the line voltage switch.
3. Attach the Calibrator to the power source using a power cable that will mate with power source outlet.

Accessing the Fuses

The Calibrator uses fuses to protect both the line-power input and measurement inputs. The following sections describe the replacement procedures and lists the appropriate fuses used in the Calibrator.

Line-Power Fuse

The Calibrator has a line-power fuse in series with the power supply. Table 2 indicates the proper fuse for each line voltage selection. This fuse is located on the rear panel.

To replace this fuse:

1. Unplug the power cord from the Calibrator.
2. Locate the fuse holder on the rear panel of the Calibrator labeled "Power Fuse".
3. Using a flat-blade screwdriver, unscrew the fuse holder using the slot on the end of the fuse holder.
4. Replace the fuse with one that is rated for the line voltage selected. See Table 2.
5. Reinsert the fuse holder and screw it into the socket.

⚠⚠ Warning

To avoid electric shock or fire, do not use makeshift fuses or short-circuit the fuse holder.

Table 2. Line Power Fuses

Line Voltage Selection	Fuse	Fluke Part No.
115 Volts	T4AH250V	2743488
230 Volts	T2AH250V	2743495

Measurement Input Fuses

The Amps (A) terminal of the METER input, the HI terminal of the OUPUT terminals, and the L terminal or the RCD terminals are protected by fuses at the rear of the Calibrator.

To replace these fuses:

1. Unplug the power cord from the Calibrator.
2. Locate the fuse holder for the measurement input on the rear panel of the Calibrator.
3. Using a flat-blade screwdriver, unscrew the fuse holder using the slot on the end of the fuse holder.
4. Replace the fuse with one that is rated for the selected input. See Table 3.
5. Reinsert the fuse holder and screw it into the socket.

⚠ Caution

To avoid damaging the Calibrator, use only the fuse specified for each of the measurement inputs.

Table 3. Measurement Input Fuses

Input	Fuse	Fluke Part No.
RCD	F3.15L 250V	2743508
Leakage Current	F100mAL 250V	2743513
Meter	F20L 500V	2743536
Loop/Line Impedance	T4AL 250V	2743524

Connecting to Line Power

⚠⚠ Warning

To avoid shock hazard, connect the factory supplied three-conductor line power cord to a properly grounded power outlet. Do not use a two-conductor adapter or extension cord; this will break the protective ground connection. If a two-conductor power cord must be used, a protective grounding wire must be connected between the ground terminal on the rear panel and earth ground before connecting the power cord or operating the instrument.

After you verify that the line voltage selection switches are set to the correct positions, verify that the correct fuse for that line voltage is installed. Connect the Calibrator to a properly grounded three-prong outlet.

Table 4. Line Power Cord Types Available from Fluke

Type	Voltage	Fluke Part No.
North America/Japan	120 V	2743310
Universal Euro	240 V	2743331
United Kingdom	240 V	2743322
Australia/China	240 V	2743346
South Africa/India	240 V	2743354

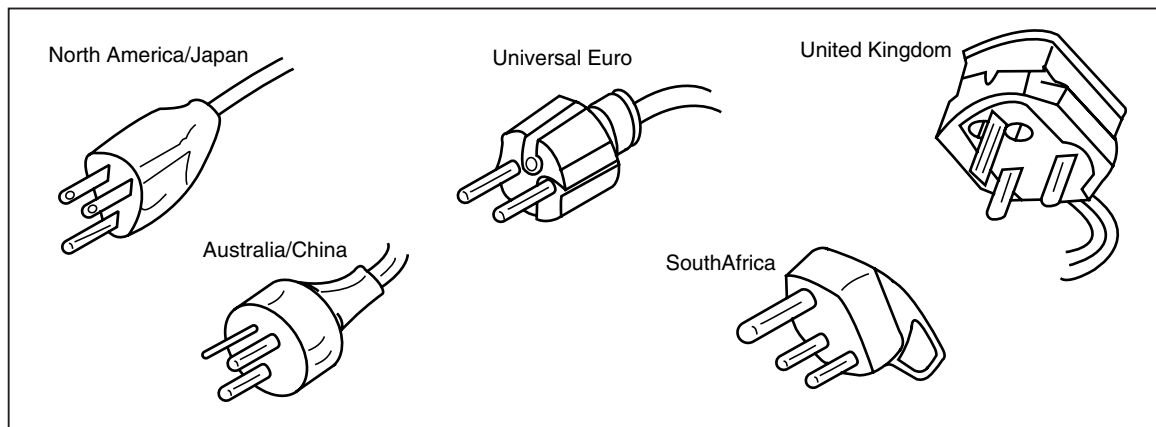

Figure 1. Line Power Cords Types Available from Fluke

ehq050.eps

Calibrator Safety Class Rating

The Calibrator is rated for 1000 V CAT I and 300 V CAT II measurement categories.

⚠ Caution

To avoid damage to the Calibrator, do not measure mains in CAT III or CAT IV environments. The Calibrator is protected for CAT I 1000 V and CAT II 300 V environments.

Description of IEC 61010 Measurement Categories

The IEC 61010 safety standard defines four Overvoltage (Installation) Categories (CAT I to CAT IV) based on the magnitude of danger from transient impulses as shown in Figure 2.

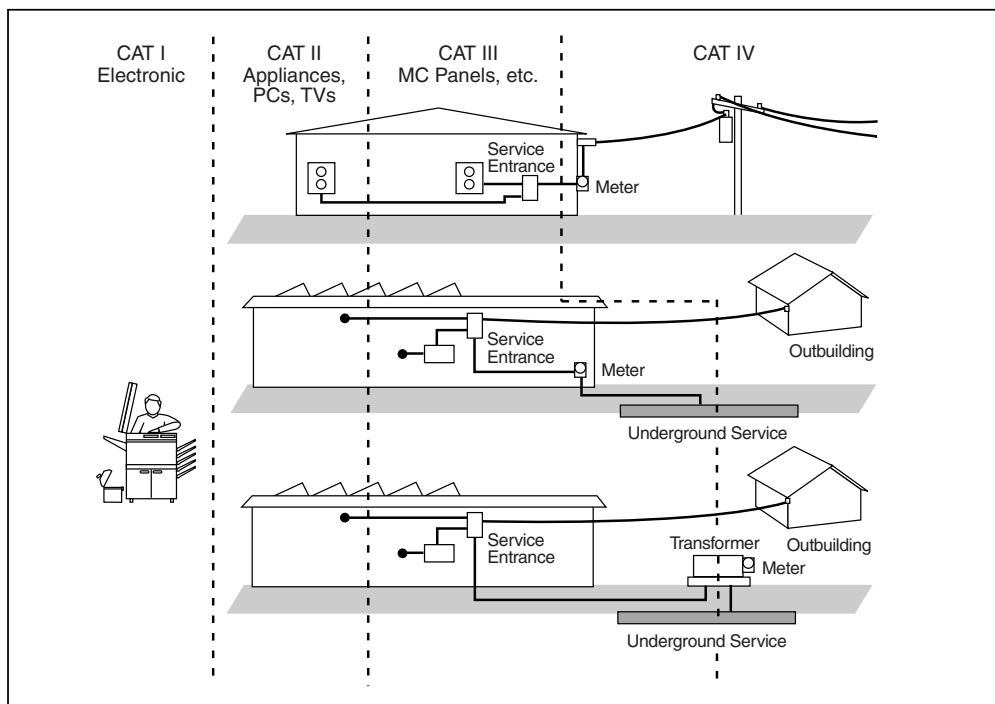

Figure 2. IEC 61010 Measurement Category (CAT) Levels

cat_levels.eps

The IEC 61010 Measurement CAT level indicates the level of protection the instrument provides against impulse withstand voltage.

CAT I equipment is designed to protect against transients from high-voltage, low-energy sources, such as electronic circuits or a copy machine.

CAT II equipment is designed to protect against transients from energy-consuming equipment supplied from the fixed installation, such as TVs, PCs, portable tools, and other household appliances.

CAT III equipment is designed to protect against transients in equipment in fixed equipment installations, such as distribution panels, feeders and short branch circuits, and lighting systems in large buildings.

CAT IV equipment is designed to protect against transients from the primary supply level, such as an electricity meter or an overhead or underground utility service.

Front-Panel Features

Table 5 lists the controls and terminals found on the front panel.

Table 5. Front-Panel Features

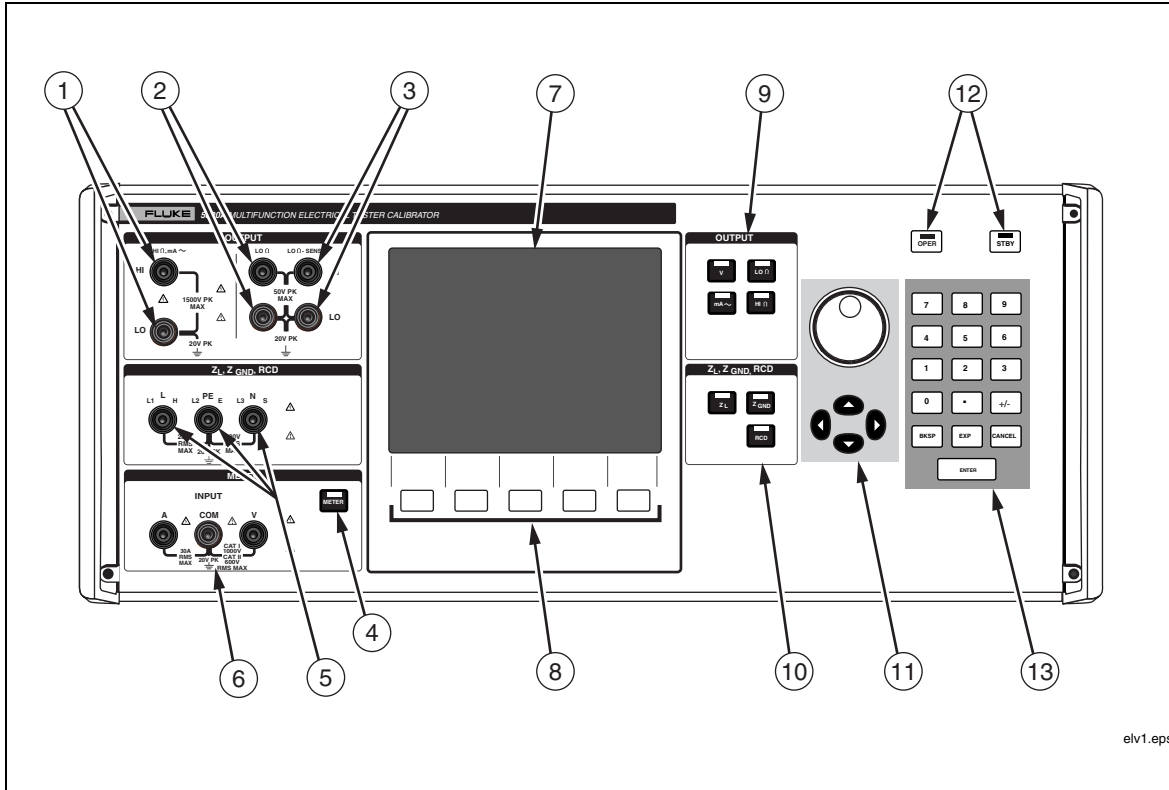

elv1.eps

Item	Description
① OUTPUT Terminals	<p>⚠⚠ Warning</p> <p>Electric shock hazard. Lethal voltages are either applied to or supplied from these terminals when the Calibrator is operating. Ensure the Calibrator and UUT is in standby mode before connecting or removing leads to these terminals. Up to 600 V ac or dc is supplied from these terminals when the Voltage function is operating.</p> <p>Provides connection points for ac and dc voltage and current as well as high resistance.</p>
② LOΩ Terminals	<p>Provides connection points for low resistance. Use these two source terminals for 2-wire ohms measurements. They are also source terminals for 4-wire measurements.</p>
③ LOΩ Sense Terminals	<p>Provides connection points for the sensing of low resistance in 4-wire measurements.</p>
④ 	<p>Selects the meter function.</p>

Table 5. Front-Panel Features (cont.)



























Item	Description								
⑤ Impedance & RCD Terminals	<p style="text-align: center;">⚠⚠ Warning</p> <p>Electric shock hazard. Lethal voltages are either applied to or supplied from these terminals when the Calibrator is operating. Ensure the Calibrator and UUT is in standby mode before connecting or removing leads to these terminals. AC Line Voltage is supplied from these terminals when the Calibrator is performing a Loop Impedance, Line Impedance or RCD calibration.</p> <p>Provides connection points for the Loop and Line impedance testing as well as RCD testing.</p>								
⑥ METER Terminals	Provides connection points for meter measurements. The V terminal is for ac and dc voltages. The A terminal is for ac and dc currents. The COM terminal is the return for all meter measurements.								
⑦ Display Panel	The display panel is a 16-color active LCD display used to display Calibrator status, output levels, measured voltage, resistance and current and active terminals. In addition, the bottom line of the display indicates the function of the five softkeys just below the display panel. See the <i>Display Panel</i> section below for more details on the displayed information.								
⑧ Softkeys	The functions of the five unlabeled softkeys are identified by labels on the Control Display directly above each key. The functions change during operation so that many different functions are accessible through these keys. A group of softkey labels is called a menu. A group of interconnected menus is called a menu tree.								
⑨ Output Function Keys	<p>Selects the output function. The output functions are:</p> <table style="border: none;"> <tr> <td style="text-align: center;"></td> <td>AC/DC Voltage Calibration (5320A/VLC only)</td> </tr> <tr> <td style="text-align: center;"></td> <td>Low Resistance</td> </tr> <tr> <td style="text-align: center;"></td> <td>Leakage Current</td> </tr> <tr> <td style="text-align: center;"></td> <td>High Resistance</td> </tr> </table>		AC/DC Voltage Calibration (5320A/VLC only)		Low Resistance		Leakage Current		High Resistance
	AC/DC Voltage Calibration (5320A/VLC only)								
	Low Resistance								
	Leakage Current								
	High Resistance								
⑩ Impedance/RCD Keys	<p>Selects the impedance and RCD functions. These functions are:</p> <table style="border: none;"> <tr> <td style="text-align: center;"></td> <td>Loop/Line Impedance</td> </tr> <tr> <td style="text-align: center;"></td> <td>Ground Bond Resistance</td> </tr> <tr> <td style="text-align: center;"></td> <td>RCD Time & Trip current</td> </tr> </table>		Loop/Line Impedance		Ground Bond Resistance		RCD Time & Trip current		
	Loop/Line Impedance								
	Ground Bond Resistance								
	RCD Time & Trip current								

Table 5. Front-Panel Features (cont.)

Item	Description
	<p>The output adjustment controls. If any of these keys are pressed or the knob is rotated, a digit on the Output Display becomes highlighted and the output increments or decrements as the knob is rotated. If a digit rolls past 0 or 9, the digit to its left or right is carried.</p> <p>When making a menu selection, pushing in on the knob is equivalent to pressing the SELECT softkey. When editing a number, pushing in on the knob will switch between moving the cursor between characters and changing the selected character's value. Arrow icons above and below the selected digit indicate which of the two modes are active.</p> <p>The  and  keys adjust the magnitude of changes by moving the highlighted digit. The  and  keys increment and decrement respectively the value of the selected digit.</p>
	<p>Controls the application of output signals to the output terminals. The OPER and STBY have LEDs imbedded in them to indicate whether or not the output signal is applied (Operate) or not (Standby).</p>
	<p>Contains number keys for keying in the output amplitude, selecting menu items, as well as other data such as the time and date. To enter a value, press the digits of the output value, a multiplier key if necessary, and an output function key; then press ENTER.</p>

Warning

To avoid electric shock, ensure the Calibrator is in standby before making connections to the following terminals:

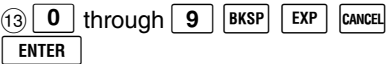
- HI and LO OUTPUT terminals for the Voltage function have up to 600 V ac or dc in operate mode.
- L, PE and N terminals have line voltage present when in operate for the RCD and Z_L modes.

Display Features

Table 6 lists the different areas of the display and the information contained in them.

Table 6. Display Features

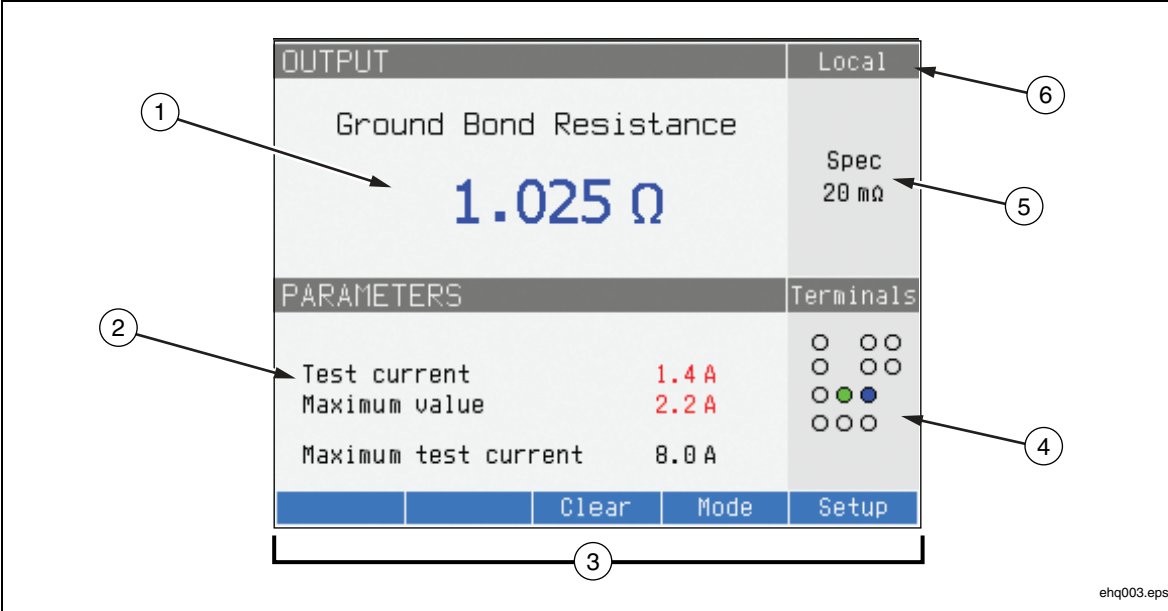

Item	Description
① Input/Output	Displays the selected function and their parameters.
② Parameters	Displays auxiliary measurements and parameters for the selected function. ⁽¹⁾
③ Softkey labels	Displays the labels for the five soft keys below the display.
④ Terminals	Displays the active terminals for the selected function.
⑤ Specifications	Displays the accuracy of the output signal or measured parameter. If the Calibrator is outputting two signals, two accuracy specifications are displayed here.
⑥ Local/Remote	Displays which of the two modes the Calibrator is set.

Display Colors: A set of common rules are used to apply color to labels and values appearing in the display.

1. Red denotes a value that is measured or scanned by the Calibrator (2.2 A in this example).
2. Blue denotes a value or parameter that can be set or changed through the front-panel keyboard or a setup function (100.25 mΩ in this example).
3. Black denotes fixed values, labels, notes or parameters which cannot be modified (8 A in this example).
4. White on a Blue field is always used for softkey labels.

Rear-Panel Features

Table 7 lists the items found on the Calibrator's rear panel.

Table 7. Rear-Panel Features

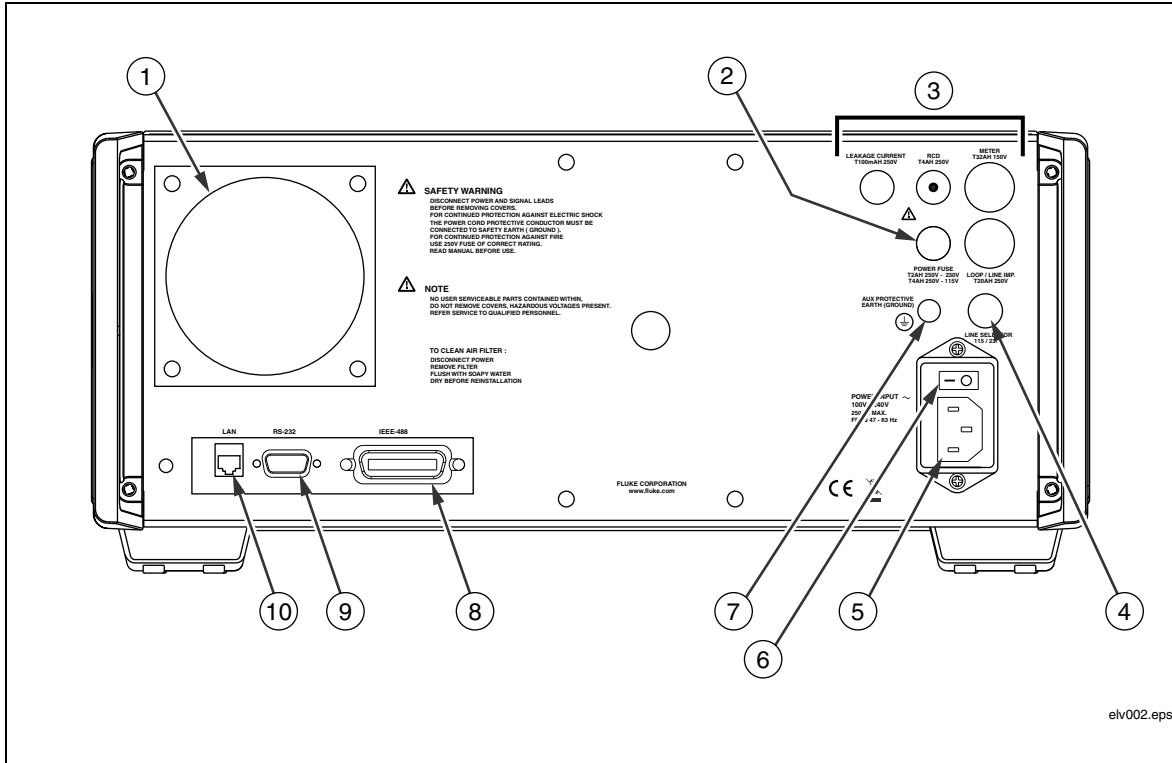

Item	Description
① Fan Filter	The filter covers the air intake to keep dust and debris out of the chassis. A fan inside the Calibrator provides a constant cooling air flow throughout the chassis.
② Line Power Fuse Holder	The line power fuse. Refer to “Accessing the Fuses” earlier in this manual.
③ Signal Fuse Holders	These fuses protect the signal outputs and inputs. Refer to “Accessing the Fuses” earlier in this manual.
④ Line Voltage Selection Switch	Selects the line voltage. Refer to Selecting Line Voltage earlier in the manual.
⑤ AC Power Input Connector	A grounded male three-prong connector that accepts the line power cord.
⑥ AC Power Switch	Turns Calibrator ac power on and off.

Table 7. Rear-Panel Features (cont.)

Item	Description
⑦ Chassis Ground Binding Post	A binding post that is internally grounded to the chassis. If the Calibrator is the ground reference point in a system, this binding post can be used for connecting other instruments to earth ground. (The chassis is normally connected to earth ground through the three conductor line cord instead of through the earth ground binding post.)
⑧ IEEE-488 Connector	A standard interface connector for operating the Calibrator in remote control as a Talker or Listener on the IEEE-488 Bus. Refer to Chapter 5 of the Users Manual for bus connection and remote programming instructions.
⑨ RS-232	A female (DCE) serial port connector for transmitting internal calibration constant data to a printer, monitor, or host computer, and for remote control of the Calibrator. Chapter 5 of the Users Manual describes proper cabling, how to set up the serial interface, and how to transmit data from the Calibrator.
⑩ LAN Connector	An RJ45 LAN connector for remote control of the Calibrator. Chapter 5 of the Users Manual describes proper cabling, how to set up the LAN interface, and how to transmit data from the Calibrator.

Turning on the Calibrator

With the Calibrator setup for the proper line voltage, press the power switch on the back panel so the “I” side of the switch is depressed. During its power-up cycle, the Calibrator displays a power supply test screen while initializing internal circuits and checking the mains connection. The screen in Figure 2 is displayed when the Calibrator completes these tests.

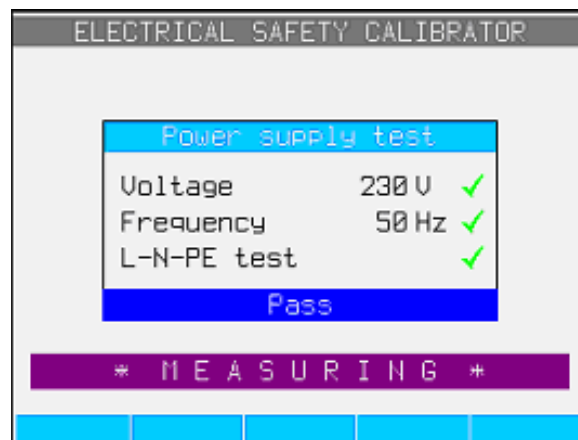
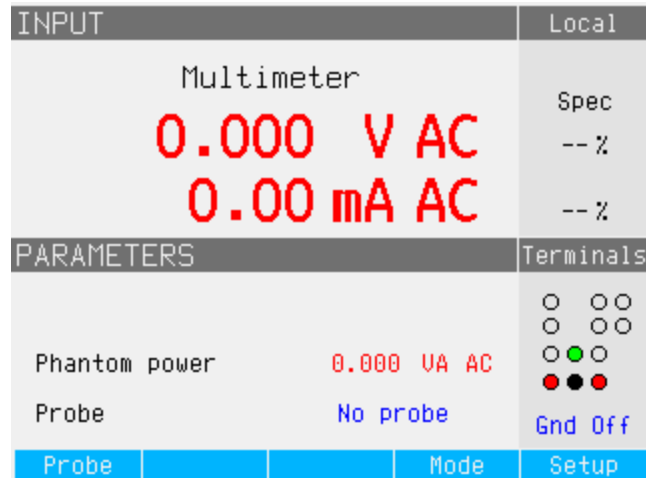

Figure 3. Power-up Test Results Screen

ehq020.bmp



ehq050.bmp

Figure 4. Meter Mode (Reference State) Display

If the Calibrator detects that the power line is improperly connected, such as line or hot wire crossed with the neutral wire, it will display “Fail”. In this case, remove the power cord and correct the problem before trying to turn the Calibrator on. If all tests pass and the power line is properly connected, the Calibrator will display “Pass” for several seconds while it performs additional internal circuitry tests.

When the initialization tests finish, the Calibrator resets to a reference state of Meter mode operation.

Note

The Calibrator resets to its reference state whenever line power is removed and then reapplied to the Calibrator.

Table 8. Function Default Settings

Function	Button	Default Value	Parameter
AC/DC Voltage Calibrator (5320A/VLC only)		10 V ac	f = 50 Hz
Low Resistance Source		1 kΩ	
Leakage Current		1 mA	
High Resistance Source		100 MΩ	
Loop/Line Impedance		1.8 kΩ	
Ground Bond Resistance		1.8 kΩ	
RCD Testing		100 mA	100 ms
Multimeter		Volts AC	

Warm Up

Once the Calibrator reaches the startup reference state, it can be used for calibration. However, the Calibrator will only make calibrations to its specified accuracy after it has been allowed to warm-up for at least 30 minutes. During these first 30 minutes, the

Calibrator itself cannot be calibrated. If calibration is attempted during this period, the Calibrator will display “cannot access the calibration”.

Accessories

Table 9 lists the available accessories for the Calibrator.

Table 9. Accessories

Model	Description
5320CASE	Transit case for 5320A Calibrator
Y5320	Rack mount kit for mounting a 5320A in a standard 19 inch rack.

